





## ORIGINAL ARTICLE

DOI 10.58430/jib.v129i1.7



# A continuous mashing system controlled by mean residence time

• Patrick Wefing <sup>1</sup>  • Marc Trilling <sup>1</sup>  • Arthur Gossen <sup>1</sup>  
• Peter Neubauer <sup>2</sup>  • Jan Schneider <sup>1</sup> 

<sup>1</sup> Institute for Life Science Technologies North Rhine-Westphalia (ILT.NRW), Technische Hochschule Ostwestfalen-Lippe, Campusallee 12, 32657 Lemgo, Germany

<sup>2</sup> Technische Universität Berlin, Department of Biotechnology, Chair of Bioprocess Engineering, Ackerstraße 76, 13355 Berlin, Germany

 patrickwefing@googlemail.com



This is an open access article distributed under the terms of the creative commons attribution-non-commercial-no-derivatives license (<http://creativecommons.org/licenses/by-nc-nd/4.0/>), which permits non-commercial re-use, distribution, and reproduction in any medium, provided the original work is properly cited, and is not altered, transformed or built upon in any way.

## Abstract

Continuous processes offer more environmentally friendlier beer production compared to batch production. However, the continuous production of mashing has not become state-of-the-art in the brewing industry. The controllability and flexibility of this process still has hurdles for practical implementation, but which are necessary to react to changing raw materials. Once overcome, continuous mashing can be efficiently adapted to the raw materials. Both mean residence time and temperature were investigated as key parameters to influence the extract and fermentable sugar content of the wort. The continuous mashing process was implemented a continuous stirred tank reactor (CSTR) cascade consisting of mashing in (20°C), protein rest (50°C),  $\beta$ -amylase rest (62-64°C), saccharification rest (72°C) and mashing out (78°C). Two different temperature settings for the  $\beta$ -amylase rest were investigated with particular emphasis on fermentable sugars. Analysis of Variance (ANOVA) and post-hoc analysis showed that the mean residence time and temperature settings were suitable control parameters for fermentable sugars. In the experimental conditions, the most pronounced effect was with the  $\beta$ -amylase rest. These results broaden the understanding of heterogenous CSTR mashing systems including assembly and selection of process parameters.

## Keywords:

Continuous mashing, continuous stirred tank reactor (CSTR), mean residence time, fermentable sugar.

## Introduction

Operations involved in beer production include malting, mashing, and fermentation. During mashing, carbohydrates and proteins in the malt are converted to simple sugars and amino acids by the enzyme in the malt. The hydrolysis of starch into fermentable sugars by enzymes such as  $\alpha$ -amylase,  $\beta$ -amylase, limit dextrinase and  $\alpha$ -glucosidase (Koljonen et al. 1995; Ziegler 1999; MacGregor et al. 1999; Ma et al 2000; Yin et al 2002; Osman 2002; Brandam et al. 2003; Bamforth 2009; Gupta et al. 2010; Steiner et al. 2011; Quek et al. 2019; Wefing et al. 2020) is fundamental for subsequent alcohol production during fermentation by yeast. Accordingly, mashing can be described as a multi enzyme reaction system which also includes physical and chemical reactions. Furthermore, mashing has an impact on beer flavour and therefore on the consumers acceptance (Bamforth 2009).

Globally, beer production is a batch process. Development of a continuous mashing process could contribute to more economic beer production (Strobl 2020) provided that the process can be sufficiently controlled. The main advantages of continuous processes are (i) smaller reactors, pumps, heat exchanger, and valves; (ii) heat recovery; (iii) consistent energy consumption without peaks; (iv) reduced need for cleaning.

Continuous mashing processes have been explored since the 1920s (Silhavy and Saginaw 1938; Cook and Davis 1960; Watts et al. 1964; Hudson and Button. 1968; Huppmann. 1969; Kehse and Jess. 1974; Moll et al. 1976; Mulder 2012; Mulder and Snip 2018). However, the complexity of the mashing process has prevented stable industrial implementation. Reliable continuous systems have been established for processes before and after mashing, including milling, mash filtration, wort boiling, hot trub separation and the chilling/aeration of wort (Willaert and Baron 2001; Hertel and Sommer 2016; Kempfert 2016; Wefing et al 2020). A suitably controlled continuous mashing process would be a significant development in an efficient continuous wort production that can adjust to the changing properties of raw materials.

The continuous mashing systems reported in literature include horizontal, vertical, plug-flow and continuous stirred tank reactors (CSTR) (Silhavy and Saginaw 1938; Cook and Davis 1960; Watts et al, 1964; Hudson and Button 1968; Huppmann, 1969; Kehse and Jess 1974; Moll et al. 1976; Mulder 2012; Mulder and Snip 2018). The implementation of a CSTR cascade would support a flexible continuous mashing, as the fill level of the individual continuous stirred tank reactors can be used to control sugar production in the process by altering the reaction time.

Continuous stirred tank reactors are typically controlled on the basis of mathematical modelling (Malar and Thyagarajan 2009; Singh and Sharma 2013; Bancila et al. 2021; Colbu et al. 2021). Numerous models describing the fermentable sugar formation by starch hydrolysis in the mashing process can be found (Muller 1991; Koljonen et al. 1992; 1995; Brandam et al. 2003; Wefing et al. 2020). A semi-empirical, model proven to predict fermentable sugar concentration ( $c_{FS}$ ) in a continuously conducted  $\beta$ -amylase rest has been reported (Wefing et al. 2020):

$$c_{FS}(t) = c_{FS,i} + C_{st,0} \cdot (1 - e^{-\alpha t}) \quad (\text{Eqn.1})$$

$$\text{with } \alpha \text{ as: } \alpha = (k_a \cdot \alpha_a + k_b \cdot \alpha_b + k_{LD} \cdot \alpha_{LD}) \quad (\text{Eqn.2})$$

Here,  $c_{FS,i}$  describes the concentration of fermentable sugar at the beginning of the mashing process, and  $C_{st,0}$  the concentration of starch that can potentially be converted into fermentable sugars. The kinetic factors of the enzymes  $\alpha$ -amylase,  $\beta$ -amylase, and limit dextrinase are represented by  $k_a$ ,  $k_b$ ,  $k_{LD}$ , whereas the enzymatic activities of the enzymes are represented by  $\alpha_a$ ,  $\alpha_b$ ,  $\alpha_{LD}$ .

The concentration of fermentable sugars in the continuous  $\beta$ -amylase rest is then calculated by combining the residence time distribution (RTD), represented as exit age distribution E (Martin 2000; Toftgaard Pedersen et al. 2017)

$$c_{FS} = \int_0^{\infty} E(t) \cdot c_{FS}(t) \cdot dt \quad (\text{Eqn.3})$$

$$\text{with: } E(t) = \frac{c_{\text{tracer}}(t)}{\int_{t=0}^{t=\infty} c_{\text{tracer}}(t) dt} \quad (\text{Eqn.4})$$

The direct application of the model to control a mashing process is prevented by the hurdle that the RTD can only be determined by tracer experiments (Roussinova and Kresta, 2008). However, previous work provides the technological and scientific foundation for the application of the mean residence time to control the continuous mashing system described here. The mean residence time ( $t_m$ ) of the CSTRs can be altered by variation of (i) flow rate ( $\dot{V}$ ) and (ii) reactor volume  $V_r$  (De Ruyck 1997; Roussinova and Kresta 2008):

$$t_m = \frac{V_r}{\dot{V}} \quad (\text{Eqn.5})$$

In contrast to the RTD, the mean residence time ( $t_m$ ) does not consider the design specific characteristics of a CSTR system. These characteristics include the reactor design, the inlet and outlet position, and mixing effects (Roussinova and Kresta 2008). Accordingly, the mean residence time describes the average behaviour of a volume elements inside a CSTR with a lower quality than the residence time distribution. The mean residence time describes the average time a volume element lasts in a CSTR. Nevertheless, the mean residence time calculation is minor compared with the experimental effort for a RTD determination.

Therefore, if fermentable sugar concentrations can be controlled during mash production, the control of the continuous mashing process by the mean residence time may be reasonable.

Here, a novel continuous mashing system with a heterogeneous CSTR cascade enabling control of extract, maltose, and glucose levels was investigated. Various mean residence time settings, and other factors that influence the fluidic behaviour inside a CSTR were examined. Additionally, enzymatic conversion rates were considered as being affected by temperature changes.

In a continuous approach the three conversion steps in a conventional batch mashing process were considered. Firstly, (i) a protein rest optimised for  $\beta$ -glucan degradation by  $\beta$ -glucanase which is important with poorly modified malts (Wefing et al. 2020). Although normally performed at 48-52°C (Steiner et al. 2011), 38°C can be used (Jones and Marinac 2002; Jones, 2005) with a final conversion step at 72°C (Jones and Marinac 2002). The second phase (ii) - the  $\beta$ -amylase rest - performed at 62-65°C (Hui 2007), with the third phase (iii) a saccharification rest, performed at 70-75°C (Hui 2007). Additionally, a terminal production step, a continuous mashing out step was included (78°C).

The different temperature zones for the four mashing steps are considered as independent but inter-connected within the continuous stirred tank reactors (Figure 1).

**Figure 1.**

**Schematic of the continuous mashing process and the RTD curves (for ideal CSTRs) that the different temperature zones can be interpreted as individual and completed reaction steps. Applying two CSTRs for the  $\beta$ -amylase rest changes the RTD curve for that process step.**

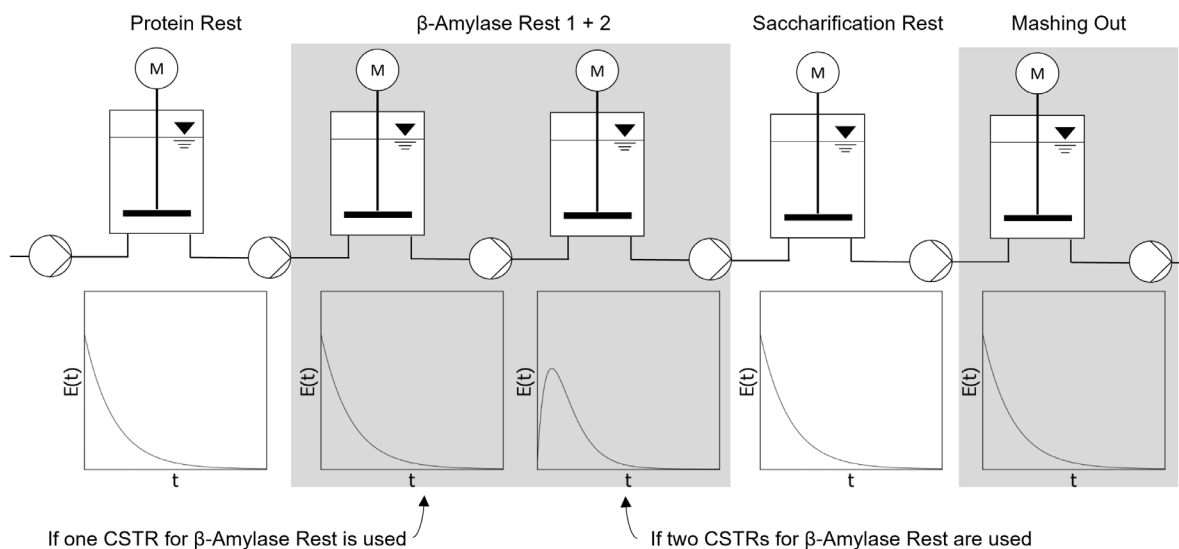

Further, the number of reactors used for each temperature zone influences the RTD of the individual steps. In this study (Figure 1), a single CSTR and a CSTR cascade consisting of two reactors is alternatively used for the  $\beta$ -amylase rest stage. The different setups result in different RTD curve shapes for the production step, represented as the exit age distribution function  $E(t)$ . This affects the movement time of the volume elements through the system and plays a role in the understanding and evaluation of the controllability of the whole system.

This work uses the mean residence time as control parameter for the fermentable sugar content (maltose, glucose, and extract). Although an approximation, the mean residence time ( $t_m$ ) may predict the 'real' mean residence time with varying accuracy for several CSTRs. The effect of different mean residence time settings was investigated by observing the fermentable sugar formation during the  $\beta$ -amylase rest, and at the end of the whole reactor cascade. Further, different temperature settings in the  $\beta$ -amylase rest stage were investigated to observe different starch conversation rates.

## Materials and methods

### Mash preparation

For mash preparation, demineralised water (brewing liquor) and finely ground malt (Pilsner malt, Weyermann, Germany) was blended with finely ground unmalted barley (Ireks, Germany) at a ratio of 1:1. Unmalted barley has a lower enzymatic activity compared to malt. Therefore, a mixture of unmalted barley and malt has a reduced capacity for starch degradation compared to 100% malt. Consequently, longer mashing times are needed to compensate for the reduced starch degradation rate. This enables a continuous mashing system to use longer residence times.

Malt and barley were ground with a dynamic (rotor) impact mill (Mühlomat 100, Mück Sondermaschinenbau GmbH, Germany). A sieve analysis was conducted after blending malt and barley. The corresponding particle size distribution is reported in Figure 2. The grist liquor ratio of the

mash was 1:4 and the malt analysis is detailed in Table 1. The fine malt barley blend used in this work is equivalent to the malt reported in Wefing et al (2020).

### Continuous mashing system

In this work, batch mashing consisted of a protein rest (48-52°C) (Steiner et al 2011),  $\beta$ -amylase rest (62-65°C) (Hui 2007) and saccharification rest (70-75°C). This was transferred to a heterogeneous CSTR cascade laboratory-scale, self-constructed mashing system. Mashing-in (20°C) was also included. A schematic of the mashing system is shown in Figure 3A.

The continuous mashing system ('Smart Mashing Plant') consists of seven stainless steel reactors (Figure 3B). As an experimental platform, the number of CSTRs used for mashing can be changed. The mashing in CSTR volume was 2 L, while all the other CSTRs have a maximum volume of 1 L. The mash is pumped by peristaltic pumps. The internal diameter of the tubing is 4 mm. The flow rates were between 20 and 100 mL/min. The temperature settings of the CSTRs (the mashing in CSTR is not heated) is achieved by electrical heating. The continuous mashing system can deliver a beer mash production rate of 144 L/day.

Figure 2.

Particle size distribution of fine malt and barley mixture (1:1) (Wefing et al, 2020).

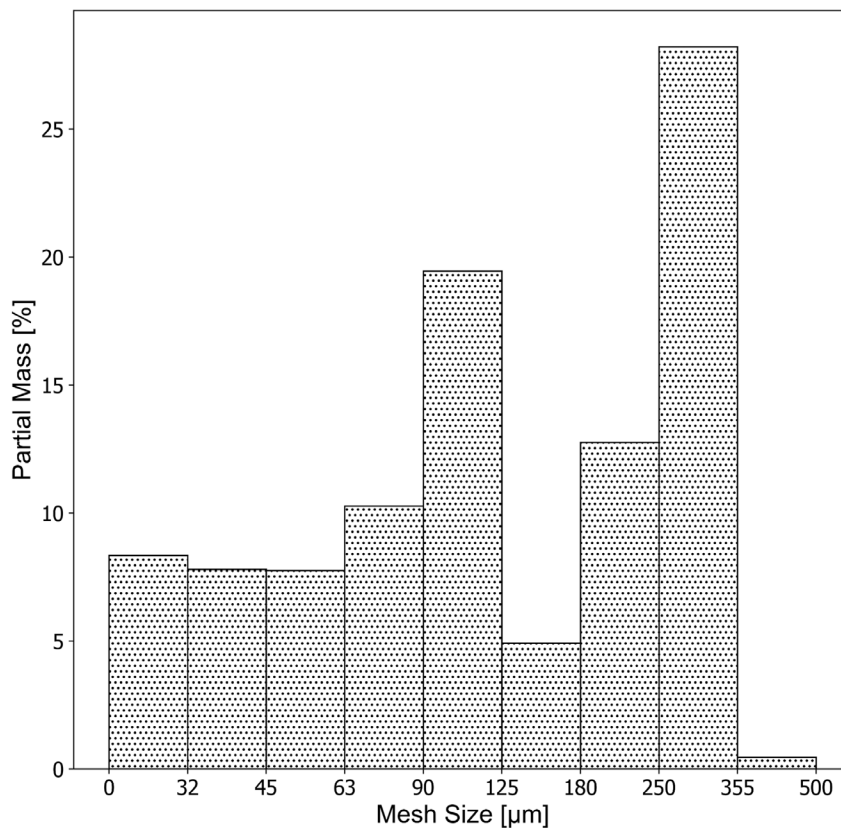

Figure 3A.

Continuous mashing system. CSTRs for the  $\beta$ -amylase rest can be varied between one and two.

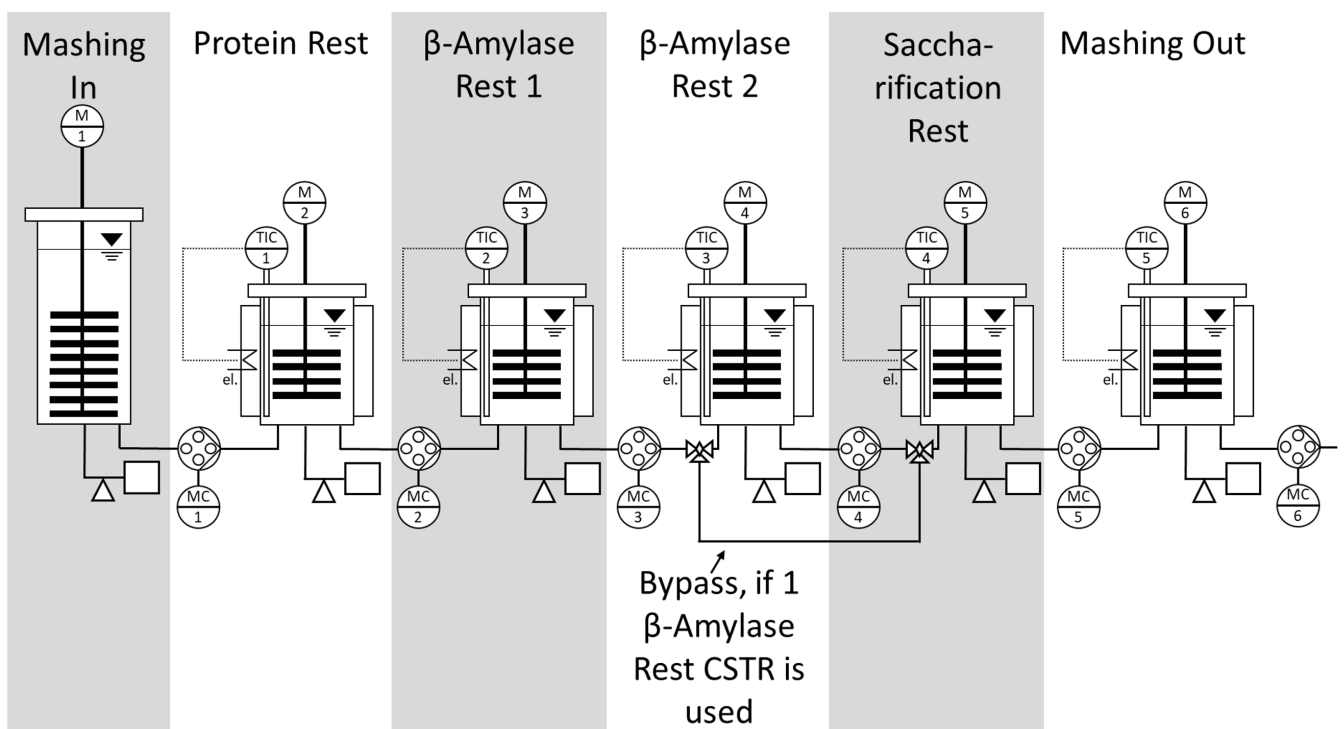



Figure 3B.

Continuous mashing enables variations in the CSTR cascade set up for continuous mashing trials.

## Continuous mashing trials

For the  $\beta$ -amylase rest stage in the continuous mashing process, several parameters were investigated - temperature (62 and 64°C), volume (300, 400, 600, and 800 mL) and number of reactors (one or two). Additionally, two different flow rates (60 and 100 mL/min) were chosen for the mashing trials. In all trials, the volume, the number of reactors and temperature were constant for the protein rest (500 mL, 50°C), saccharification rest (500 mL, 72°C) and mashing out (500 mL, 78°C).

The mash was mixed inside each continuous stirred tank reactor by oscillating agitators at a rate of 2.5Hz and a turning angle of 720°. When both CSTRs were used for the  $\beta$ -amylase rest, the volume of the CSTRs was:

$$V_r = V_{CSTR1} + V_{CSTR2} \quad (5)$$

To calculate the total mean residence time ( $t_{m,total}$ ) of the continuous mashing system, the combined volume of all used CSTRs was divided by the flow rate:

$$t_{m,total} = \frac{\sum_n^i V_{CSTR,i}}{\dot{V}} \quad (6)$$

## Analytical methods

Samples were taken after the  $\beta$ -amylase rest and after mashing out. The samples were cooled immediately in a bath of ice water. Extract was determined using a refractometer (J157 Automatic Refractometer, Rudolph Research Analytical, USA). Maltose and glucose levels were determined by high performance liquid chromatography (HPLC). Sample preparation for the HPLC included (i) clarification with a Carrez kit, (ii) centrifugation at 2000g for 5 min, (iii) isolation of the supernatant and (iv) filtration of the supernatant through a 0.2  $\mu$ m filter. A NH2-RP column (EC 250/4.6 Nucleodur 100-3, Macherey-Nagel, Germany) was used at 30°C. Peaks were analysed using a RI detector (Shimadzu, Japan).

## Statistical analysis

Glucose and maltose levels are an average of three independent measurements. Extract is the average of six independent measurements. Error bars of the glucose and maltose values represent the span of values and with extract the standard deviation. The Shapiro-Wilk test was applied to check for a normal distribution of the data (Bee Wah and Mohd Razali 2011). The effect of the mean residence time on extract, maltose and glucose concentration within

(i)  $\beta$ -amylase rest with one CSTR, (ii)  $\beta$ -amylase rest with two CSTRs, (iii) mashing out with one  $\beta$ -amylase rest CSTR and (iv) mashing out with two  $\beta$ -amylase rest CSTRs were analysed with a one-way analysis of variance (ANOVA) (Stohle and Wold 1989; Osmekhina et al. 2010; Taskila et al, 2011; Bellut et al. 2018; Katsch et al. 2020; 2021). If p-values were above 0.05, Tukey's honestly significant difference (HSD) was used as post-hoc method (Marcinkowska-Lesiak et al. 2016; Bellut et al, 2018; Martinez-Amezaga et al. 2018; Katsch et al. 2021).

The effect of different temperatures on extract, maltose and glucose concentration was analysed by Student's t-test for two independent samples (Bee Wah and Mohd Razali 2011; de Winter 2013). All calculations were executed with python (version:3.8.5). The *scipy.stats* (version: 1.8.0) libraries *scipy.stats.ttest\_ind* (Student's t-test), *scipy.stats.f\_oneway* (ANOVA), and *scipy.stats.shapiro* (Shapiro-Wilk test) were used for the calculations.

## Results

This work investigates whether the mean residence time can be used as a control parameter for extract, maltose, and glucose concentration in the continuous production of a beer mash. To show that this parameter is sufficiently sensitive to influence the concentration of fermentable sugars, volume and the flow rate were varied.

The results of mashing with a single  $\beta$ -amylase rest CSTR are presented in Figure 4 with the fermentable sugar levels against the CSTR volume (Figures 4A and B). The mean residence time ( $t_m$ ) combines CSTR volume and flow rate allowing to represent results of the individual mashing trials (Figure 4C). As shown, the concentration of maltose, glucose, and extract increase as the mean residence time increases until reaching a plateau. This observation suggests that the mean residence time is sufficiently sensitive to be used as a control parameter in the mashing process.

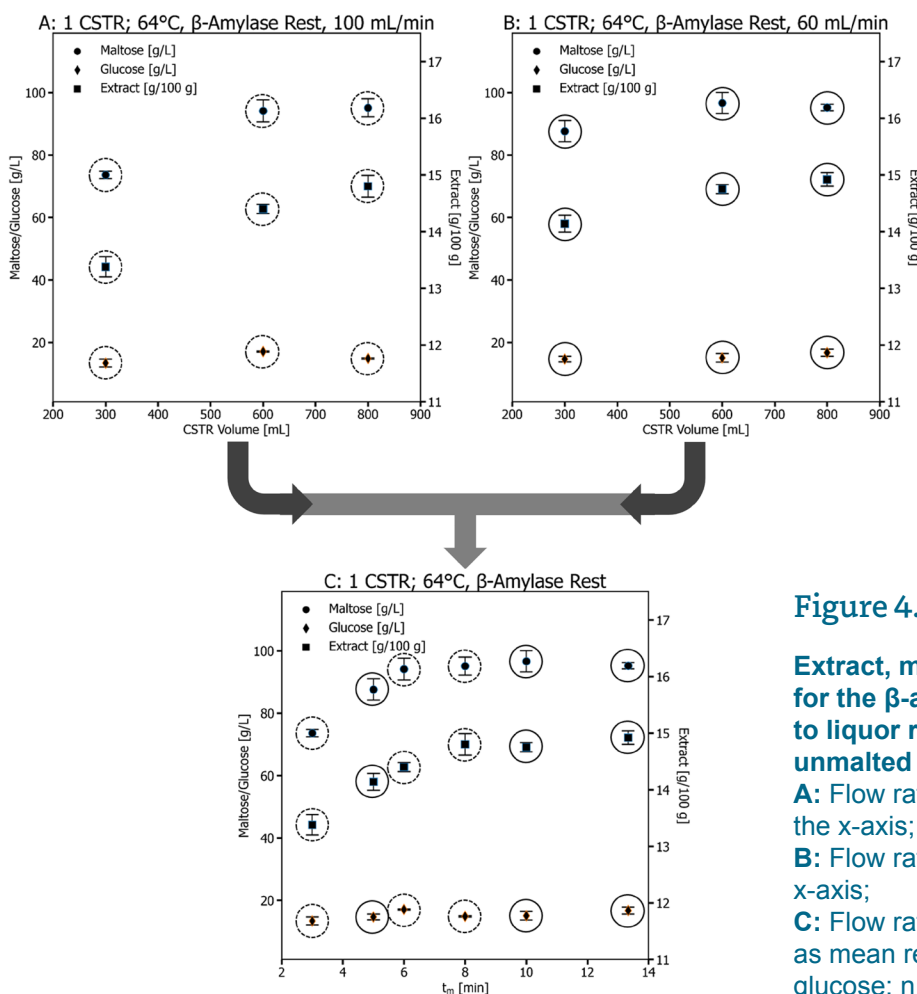

Figure 4.

**Extract, maltose, and glucose concentration for the  $\beta$ -amylase rest conducted at 64°C. Malt to liquor ratio: 1:4; 50% Pilsner fine malt, 50% unmalted barley.**

**A:** Flow rate: 100 mL/min with CSTR levels on the x-axis;

**B:** Flow rate: 60 mL/min with CSTR levels on the x-axis;

**C:** Flow rate and CSTR levels of A and B joined as mean residence time,  $t_m$  (Eqn.1). Maltose and glucose:  $n = 3$ , error bars: span of values; extract:  $n = 6$ , error bars: standard deviation.

## Continuous $\beta$ -amylase rest

### Impact of mean residence time on sugar concentration

The mean residence time can be used to change the fermentable sugar concentration in the continuous mashing process. Two different temperature settings were used to assess variations in the temperature dependent conversion rate of the diastatic power enzymes (Table 2). A one-way ANOVA was applied, to compare the mashing trials with different mean residence times and the concentration of maltose, glucose and extract. If significant differences ( $p < 0.05$ ) were found, Tukey’s HSD test was applied. The results of the post-hoc-analysis are highlighted with letters beneath the data (Table 3).

The results with a single CSTR for the  $\beta$ -amylase rest at 62 and 64°C are shown in Figure 5. Trials with a mashing temperature of 62°C yielded the lowest maltose and extract concentration at the shortest mean residence times, with the highest values at the longest mean residence times. Similar conclusions were found when the  $\beta$ -amylase rest was conducted at 64°C (Figure 5). Only slight variations in glucose concentration were found with a single CSTR for the  $\beta$ -amylase rest.

In the 62°C mashing experiments, the different residence times resulted in a significant increase of the maltose concentration.

Tukey’s HSD was used for a pairwise analysis and to categorise the different sugar levels (‘A’ to ‘E’) in Figure 5. With the 62°C trials only two significantly different levels of maltose were found (Figure 5A) and four different maltose levels were observed at 64°C (Figure 5B). This finding is consistent with the extract determination in both trials. Variation of  $t_m$  showed no effect on glucose levels for both temperatures. Therefore, extract together with maltose concentration can be controlled using the mean residence time with a single  $\beta$ -amylase rest CSTR. However, at 64°C the control was improved compared to 62°C.

The residence time distribution of a single CSTR was different to the RTD of two CSTRs in a cascade. Accordingly, it was investigated if the mean residence time is suitable as control parameter if a double CSTR setup is used for the continuous  $\beta$ -amylase rest (Figure 6). One way ANOVA revealed no significant differences in maltose and glucose concentration for the trials at 62 and 64°C. However, the extract was found to show significant differences at both temperatures. At 62°C, the highest extract value was reached with  $t_m = 13.3$  minutes. When continuous mashing was conducted at 64°C, no significant increase of sugar levels was found for  $t_m$  values higher than 8 minutes. When two CSTRs in cascade are used for the  $\beta$ -amylase rest, the extract can be controlled by the mean residence time. Post-hoc-analysis within  $p < 0.05$  showed no significant difference in levels of glucose and maltose.

$t_m$ [min]	1 CSTR, 62°C, $\beta$ -Amylase rest						1 CSTR, 64°C, $\beta$ -Amylase rest					
	Maltose [g/L]	$\pm$ [g/L]	Glucose [g/L]	$\pm$ [g/L]	Extract [g/L]	$\pm$ [g/L]	Maltose [g/L]	$\pm$ [g/L]	Glucose [g/L]	$\pm$ [g/L]	Extract [g/L]	$\pm$ [g/L]
3.00	73.63	1.16	14.19	2.34	12.52	0.30	73.63	1.16	13.38	1.26	13.38	0.18
5.00	75.42	2.79	13.78	0.70	12.76	0.30	87.61	3.42	14.63	0.92	14.14	0.15
6.00	75.94	1.35	10.96	0.89	12.75	0.12	94.14	3.48	17.03	0.20	14.40	0.08
8.00	83.68	1.54	12.27	0.44	12.87	0.11	95.10	2.86	14.83	0.22	14.80	0.19
10.00	84.88	3.30	12.22	0.51	12.85	0.11	96.65	3.41	15.05	1.41	14.75	0.08
13.33	85.46	2.80	11.45	0.83	13.16	0.12	95.21	1.03	16.72	1.14	14.92	0.12
$t_m$ [min]	2 CSTRs, 62°C, $\beta$ -Amylase rest						2 CSTRs, 64°C, $\beta$ -Amylase rest					
	Maltose [g/L]	$\pm$ [g/L]	Glucose [g/L]	$\pm$ [g/L]	Extract [g/L]	$\pm$ [g/L]	Maltose [g/L]	$\pm$ [g/L]	Glucose [g/L]	$\pm$ [g/L]	Extract [g/L]	$\pm$ [g/L]
6.00	84.70	1.59	15.03	0.90	13.64	0.14	85.37	3.13	16.17	1.33	15.07	0.14
8.00	85.26	2.75	15.04	0.96	13.80	0.14	87.69	2.12	13.34	2.38	15.27	0.09
10.00	88.04	1.90	16.15	1.06	14.12	0.16	93.28	6.58	15.84	0.93	15.47	0.17
13.33	91.22	2.10	14.93	2.42	14.36	0.09	92.47	2.19	14.95	1.01	15.36	0.04

Table 2.

Continuous  $\beta$ -amylase rest mashing trials.

Table 3.

Significance analysis of changes by the mean residence time in continuous  $\beta$ -amylase rest trials.

1 CSTR, $\beta$ -Amylase rest													
$t_m$ [min]		62°C						64°C					
		Maltose		Glucose		Extract		Maltose		Glucose		Extract	
I	II	p-Value	Reject	p-Value	Reject	p-Value	Reject	p-Value	Reject	p-Value	Reject	p-Value	Reject
		Tukey's		Tukey's		Tukey's		Tukey's		ANOVA		Tukey's	
10.00	13.00	0.872	False	0.900	False	0.054	False	0.900	False	0.370	False	0.044	True
10.00	3.00	0.001	True	0.624	True	0.507	True	0.001	True	0.370	False	0.001	True
10.00	5.00	0.004	True	0.792	True	0.900	True	0.010	True	0.370	False	0.001	True
10.00	6.00	0.006	True	0.900	True	0.720	True	0.054	False	0.370	False	0.001	True
10.00	8.00	0.519	False	0.900	False	0.900	False	0.418	False	0.370	False	0.826	False
13.00	3.00	0.006	True	0.321	True	0.001	True	0.001	True	0.370	False	0.001	True
13.00	5.00	0.026	True	0.481	True	0.005	True	0.024	True	0.370	False	0.001	True
13.00	6.00	0.036	True	0.900	True	0.001	True	0.127	False	0.370	False	0.001	True
13.00	8.00	0.983	False	0.900	False	0.102	False	0.692	False	0.370	False	0.441	False
3.00	5.00	0.935	False	0.900	False	0.900	False	0.007	True	0.370	False	0.001	True
3.00	6.00	0.867	False	0.183	False	0.900	False	0.002	True	0.370	False	0.001	True
3.00	8.00	0.017	True	0.647	True	0.345	True	0.001	True	0.370	False	0.001	True
5.00	6.00	1.000	False	0.293	False	0.900	False	0.900	False	0.370	False	0.001	True
5.00	8.00	0.080	False	0.815	False	0.817	False	0.241	False	0.370	False	0.001	True
6.00	8.00	0.109	False	0.893	False	0.565	False	0.727	False	0.370	False	0.001	True

2 CSTRs, $\beta$ -Amylase rest													
$t_m$ [min]		62°C						64°C					
		Maltose		Glucose		Extract		Maltose		Glucose		Extract	
I	II	p-Value	Reject	p-Value	Reject	p-Value	Reject	p-Value	Reject	p-Value	Reject	p-Value	Reject
		ANOVA		ANOVA		Tukey's		ANOVA		ANOVA		Tukey's	
10.00	13.00	0.092	False	0.853	False	0.005	True	0.266	False	0.399	False	0.146	False
10.00	6.00	0.092	False	0.853	False	0.001	True	0.266	False	0.399	False	0.001	True
10.00	8.00	0.092	False	0.853	False	0.007	True	0.266	False	0.399	False	0.002	True
13.00	6.00	0.092	False	0.853	False	0.001	True	0.266	False	0.399	False	0.004	True
13.00	8.00	0.092	False	0.853	False	0.001	True	0.266	False	0.399	False	0.280	False
6.00	8.00	0.092	False	0.853	False	0.313	False	0.266	False	0.399	False	0.223	False

Figure 5.

**Extract, maltose, and glucose concentrations in the continuous  $\beta$ -amylase rest with a single CSTR.**

**A:**  $\beta$ -amylase rest temperature = 62°C; **B:**  $\beta$ -amylase rest temperature = 64°C. Letters 'A' to 'E' represent the significant differences between the extract, maltose and glucose levels based on an ANOVA analysis with Tukey's HSD as post-hoc test with significance level  $p < 0.05$ ; Maltose and glucose:  $n = 3$ , error bars: span of values; extract:  $n = 6$ , error bars: standard deviation.

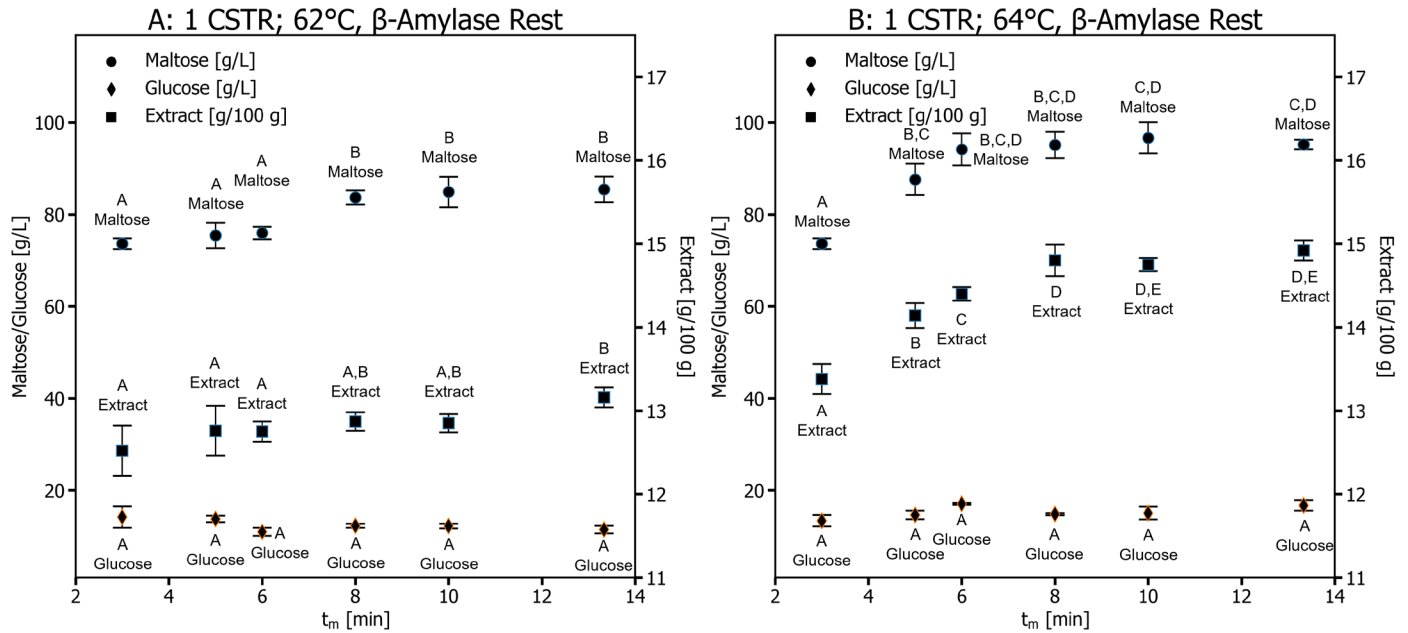
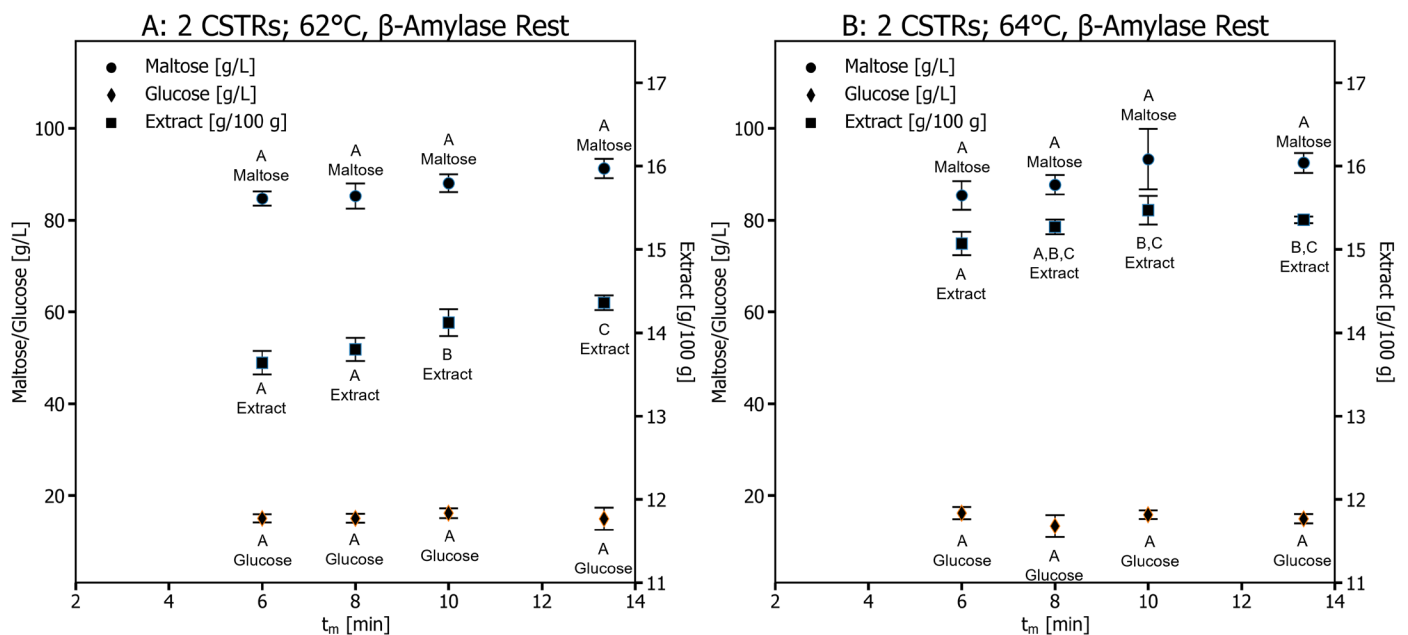

Figure 6.

**Extract, maltose, and glucose concentrations in the continuous  $\beta$ -amylase rest with a cascade of two CSTRs.**

**A:**  $\beta$ -amylase rest temperature = 62°C; **B:**  $\beta$ -amylase rest temperature = 64°C. Letters 'A' to 'C' represent significant differences between the determined extract, maltose and glucose levels based on an ANOVA analysis with Tukey's HSD as post-hoc test with significance level  $p < 0.05$ ; Maltose and glucose:  $n = 3$ , error bars: span of values; extract:  $n = 6$ , error bars: standard deviation.



## Impact of temperature on sugar levels in $\beta$ -amylase rest

The mashing trials were influenced by the selected  $\beta$ -amylase rest temperatures. Therefore, experiments were designed to explore the impact of different temperature settings on the continuous mashing process. Mashing trials with equal mean residence times but conducted at different temperatures were compared. The resulting extract, maltose, and glucose concentrations were analysed by the aid of Student's t-test. The results are shown in Table 4 and Figure 7.

With a single CSTR for the continuous  $\beta$ -amylase rest, the different temperature settings significantly ( $p < 0.05$ ) influenced the extract levels (Figure 7A). This was also found for maltose within a significance level of  $p < 0.10$ . Except for  $t_m = 3$  minutes, changes in maltose concentration were found with a significance level of  $p < 0.05$ . Similarly, glucose concentration was significantly changed ( $p < 0.05$ ) at the different temperature settings.

Because of the lower proportion of glucose in the mash compared to other fermentable sugars (Koljonen et al. 1995; Fox 2016), the differences in glucose were small compared to the differences in maltose concentration. Furthermore, the use of two CSTRs in a cascade for the  $\beta$ -amylase rest showed that the different temperature settings significantly affect extract levels (Figure 7B). Accordingly, the use of temperature as a control parameter is appropriate to change extract levels regardless of the number of CSTRs used for the  $\beta$ -amylase rest. If a single CSTR is used, both maltose and glucose concentration can be controlled by temperature.

**Figure 7.**

**Comparison of extract, maltose, and glucose concentrations in continuous  $\beta$ -amylase rests conducted at 62 and 64°C. A: single CSTR; B: two CSTRs in a cascade. The p-value describing the temperature effect (62/64°C) was determined by Student's t-test; Malt to liquor ratio: 1:4.**

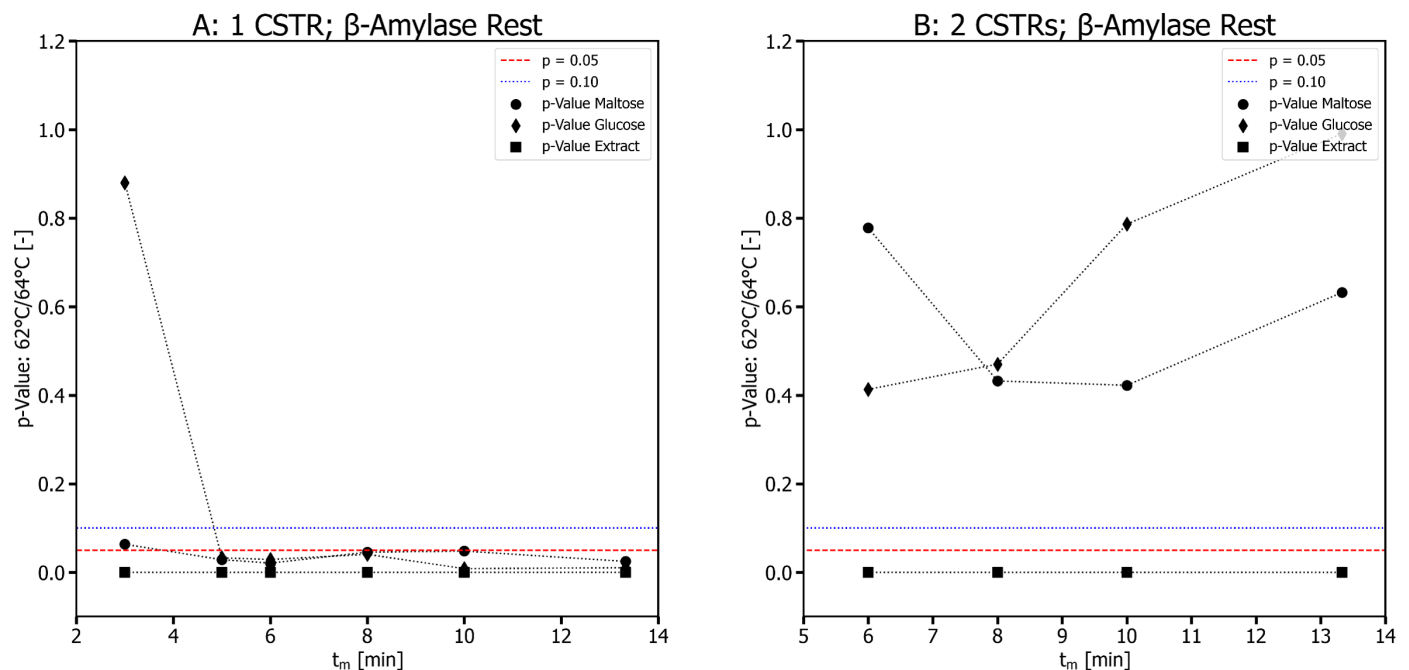

## Continuous mashing process

### Impact of the mean residence time on sugar concentration

In the continuous mashing process, most of the fermentable sugars are formed by the diastatic enzymes during  $\beta$ -amylase rest. To clarify if the saccharification rest and mashing out are influenced by the  $\beta$ -amylase rest, the mash was sampled at the end of the mashing process.

The mean residence time can be influenced by either the reactor volume or the flow rate. A flow rate change influences the mean residence time in all the interconnected CSTRs. Accordingly, a flow rate of 60 mL/min results in a combined mean residence time of 25 minutes for the protein rest (50°C), saccharification rest (72°C), and mashing out (78°C). If the flow rate is 100 mL/min, the combined mean residence time for the protein rest, saccharification rest and mashing out is 15 minutes. The total mean residence time ( $t_{m,total}$ ) results from combining the mean residence time of the  $\beta$ -amylase rest, protein rest, saccharification rest, and mashing out.

The results obtained previously showed that a single  $\beta$ -amylase rest CSTR effects different fermentable sugar levels along with a different degree of controllability compared to the double stage  $\beta$ -amylase rest CSTR. Therefore, both variants were examined individually regarding their effect on the overall mashing process.

Significant differences for maltose, glucose, and extract concentration were found with a single CSTR used for the  $\beta$ -amylase rest (Figure 8, Tables 5 & 6). Tukey's HSD analysis showed with a single CSTR for the  $\beta$ -amylase rest at 62°C, the glucose concentration was lowest at the longest residence time. Glucose values at shorter residence times showed no significant difference.

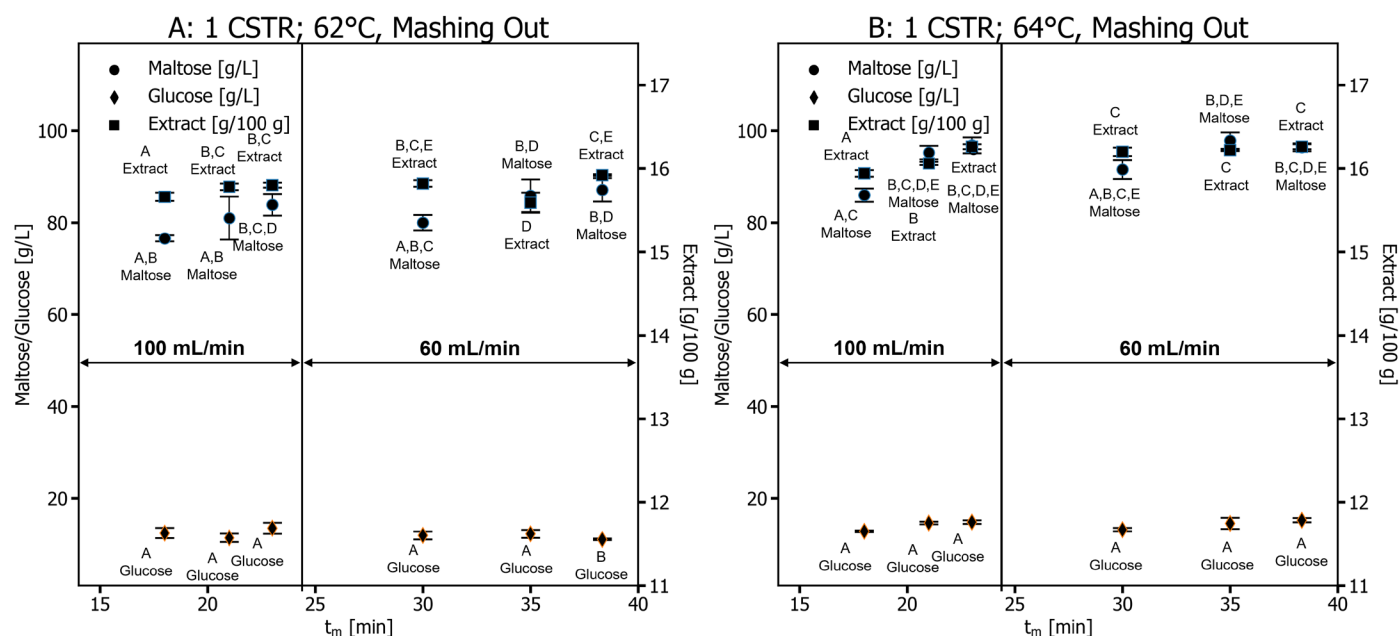

Figure 8.

### Extract, maltose, and glucose concentrations at the end of the continuous mashing process with a single CSTR for the $\beta$ -amylase rest.

**A:**  $\beta$ -amylase rest temperature = 62°C, flow rate: 100 mL/min and 60 mL/min; **B:**  $\beta$ -amylase rest temperature = 64°C, flow rate: 100 mL/min and 60 mL/min; Letters 'A' to 'E' show significant differences between the determined extract, maltose and glucose levels (ANOVA analysis with Tukey's HSD as post-hoc test with significance level  $p < 0.05$ );  $n = 3$ , error bars: span of values; extract:  $n = 6$ , error bars: standard deviation.

Table 3.

## Results of continuous mashing trials.

		1 $\beta$ -Amylase rest CSTR, 62 °C, Mashing out						1 $\beta$ -Amylase rest CSTR, 64 °C, Mashing out					
$t_m$	Flow	Maltose	$\pm$	Glucose	$\pm$	Extract	$\pm$	Maltose	$\pm$	Glucose	$\pm$	Extract	$\pm$
[min]	[mL/min]	[g/L]	[g/L]	[g/L]	[g/L]	[g/L]	[g/L]	[g/L]	[g/L]	[g/L]	[g/L]	[g/L]	[g/L]
18.00	100.00	76.56	0.68	12.45	1.11	15.66	0.05	85.97	1.46	12.82	0.21	15.94	0.04
21.00	100.00	80.96	4.66	11.42	0.91	15.78	0.04	95.23	1.47	14.64	0.31	16.06	0.02
23.00	100.00	83.88	2.35	13.50	1.21	15.80	0.03	96.80	1.73	14.85	0.41	16.26	0.03
30.00	60.00	79.97	1.67	11.92	0.87	15.82	0.04	91.51	2.06	13.18	0.37	16.20	0.05
35.00	60.00	85.84	3.54	12.26	0.87	15.59	0.12	97.83	1.76	14.55	1.23	16.22	0.01
38.33	60.00	87.11	2.55	11.06	0.17	15.92	0.01	96.39	0.86	15.25	0.47	16.26	0.03
		2 $\beta$ -Amylase rest CSTRs, 62 °C, Mashing out						2 $\beta$ -Amylase rest CSTRs, 64 °C, Mashing out					
21.00	100.00	90.66	5.24	12.66	5.24	16.22	0.05	89.30	2.96	15.12	1.22	16.11	0.04
35.00	60.00	96.21	1.03	13.10	1.03	16.37	0.02	94.27	1.92	13.14	0.46	16.33	0.04
38.33	60.00	95.59	0.98	13.01	0.98	16.32	0.07	95.18	2.01	13.87	1.13	16.26	0.06

Table 6.

## Significance analysis of changes affected by the mean residence time in continuous mashing trials.

1 $\beta$ -Amylase rest CSTR, Mashing out													
		62 °C						64 °C					
$t_m$	[min]	Maltose		Glucose		Extract		Maltose		Glucose		Extract	
		p-Value	Reject	p-Value	Reject	p-Value	Reject	p-Value	Reject	p-Value	Reject	p-Value	Reject
I	II	Tukey's		Tukey's		Tukey's		Tukey's		Tukey's		Tukey's	
10.00	13.00	0.860	False	0.001	True	0.001	True	0.900	False	0.910	False	0.674	False
10.00	3.00	0.001	True	0.900	False	0.001	True	0.001	True	0.300	False	0.001	True
10.00	5.00	0.004	True	0.900	False	0.001	True	0.035	True	0.403	False	0.900	False
10.00	6.00	0.006	True	0.900	False	0.001	True	0.671	False	0.997	False	0.001	True
10.00	8.00	0.517	False	0.900	False	0.001	True	0.900	False	0.998	False	0.674	False
13.00	3.00	0.006	True	0.001	True	0.001	True	0.001	True	0.064	False	0.001	True
13.00	5.00	0.026	True	0.001	True	0.072	False	0.135	False	0.093	False	0.370	False
13.00	6.00	0.036	True	0.001	True	0.001	True	0.900	False	0.993	False	0.001	True
13.00	8.00	0.900	False	0.001	True	0.002	True	0.900	False	0.991	False	0.900	False
3.00	5.00	0.900	False	0.900	False	0.001	True	0.073	False	1.000	False	0.001	True
3.00	6.00	0.855	False	0.900	False	0.043	True	0.002	True	0.154	False	0.001	True
3.00	8.00	0.017	True	0.900	False	0.020	True	0.001	True	0.162	False	0.001	True
5.00	6.00	0.900	False	0.900	False	0.550	False	0.348	False	0.217	False	0.001	True
5.00	8.00	0.080	False	0.900	False	0.717	False	0.093	False	0.228	False	0.370	False
6.00	8.00	0.109	False	0.770	False	0.900	False	0.900	False	1.000	False	0.001	True
2 $\beta$ -Amylase rest CSTRs, Mashing out													
		62 °C						64 °C					
$t_m$	[min]	Maltose		Glucose		Extract		Maltose		Glucose		Extract	
		p-Value	Reject	p-Value	Reject	p-Value	Reject	p-Value	Reject	p-Value	Reject	p-Value	Reject
I	II	ANOVA		ANOVA		Tukey's		ANOVA		ANOVA		Tukey's	
10.00	13.00	0.092	False	0.940	False	0.005	True	0.266	False	0.399	False	0.172	False
10.00	6.00	0.092	False	0.940	False	0.001	True	0.266	False	0.399	False	0.001	True
10.00	8.00	-	-	-	-	0.001	True	-	-	-	-	-	-
13.00	6.00	0.092	False	0.940	False	0.001	True	0.266	False	0.399	False	0.001	True
13.00	8.00	-	-	-	-	0.147	False	-	-	-	-	-	-
6.00	8.00	-	-	-	-	0.033	True	-	-	-	-	-	-

However, ANOVA confirmed that  $t_{m,total}$  had no significant influence on glucose, if the  $\beta$ -amylase rest was performed at 64°C. Five different extract levels were found when the  $\beta$ -amylase rest was at 62°C and three when the mashing temperature was set to 64°C. Different mean residence times also led to significantly different maltose levels for both  $\beta$ -amylase rest temperatures. No significant differences in glucose and maltose concentration were found at the end of the mashing process (Figure 9). Extract determination showed that significant changes in extract levels can be introduced by mean residence time regardless of the temperature of the  $\beta$ -amylase rest.

Mean residence times in the range of 3 to 5 minutes applied to the  $\beta$ -amylase rest stage resulted in the lowest extract levels after mashing out. This observation was independent whether a single CSTR or a double reactor cascade was used. Fermentable sugar concentrations were increased after saccharification and mashing out but did not reach the levels found with longer mean residence times in the  $\beta$ -amylase rest. Different mean residence times with the  $\beta$ -amylase rest showed an effect on extract and maltose concentration and can be assumed as a control parameter. However, the effect was increased when a single CSTR for the  $\beta$ -amylase rest was used.

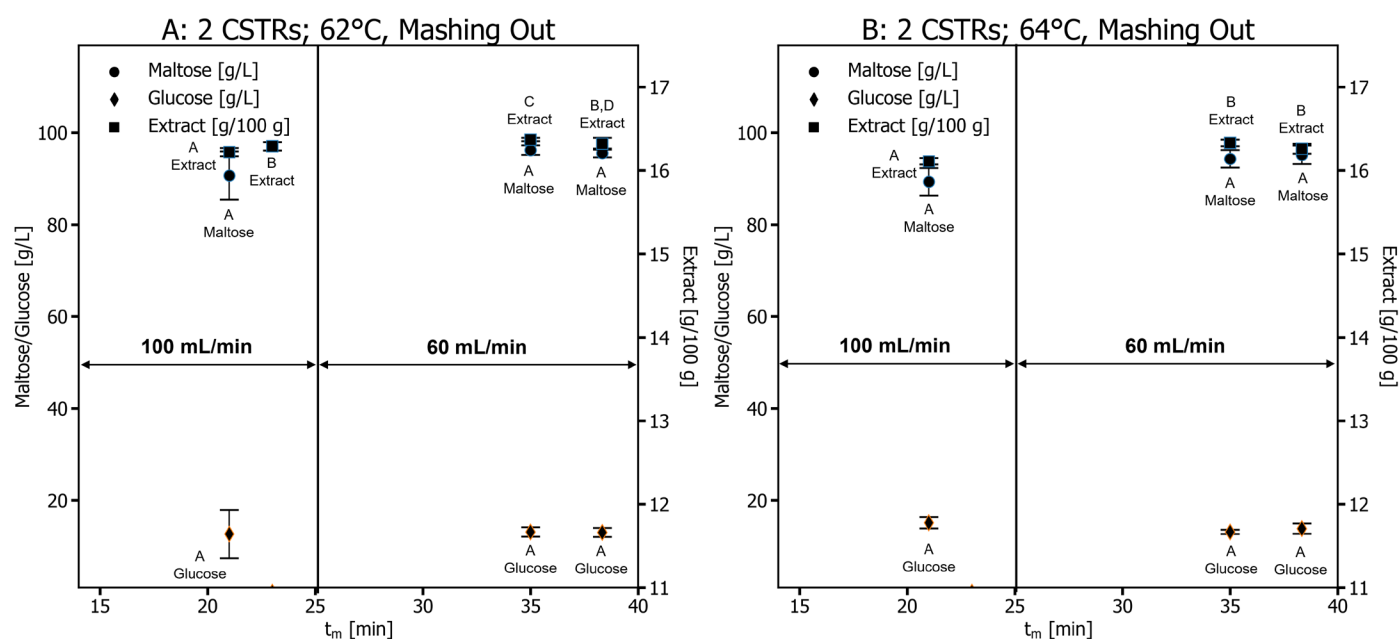

**Figure 9.**

**Extract, maltose, and glucose concentrations at the end of the continuous mashing process with two CSTRs in a cascade for the  $\beta$ -amylase rest.**

**A:**  $\beta$ -amylase rest temperature = 62°C, flow rate: 100 mL/min and 60 mL/min; **B:**  $\beta$ -amylase rest temperature = 64°C, flow rate: 100 mL/min and 60 mL/min; Letters 'A' to 'D' show significant differences between the determined extract, maltose and glucose levels (ANOVA analysis with Tukey's HSD as post-hoc test with significance level  $p < 0.05$ ); Maltose and glucose:  $n = 3$ , error bars: span of values; extract:  $n = 6$ , error bars: standard deviation.

## Impact of temperature on sugar levels during $\beta$ -amylase rest

As different temperature settings in the  $\beta$ -amylase rest stage show significant impact on fermentable sugar concentrations, its effect on the overall process was investigated. Therefore, mash samples with the same mean residence time were taken at the end of the process.

As shown in Figure 10 and Table 7, a significant difference ( $p < 0.10$ ) in extract concentration was found for all the samples. Additionally, significant differences in extract levels ( $p < 0.05$ ) were found for all the mean residence times, with the exception of  $t_{m,\text{total}} = 38.3$  minutes. Furthermore, due to temperature changes, maltose levels can be significantly influenced ( $p < 0.05$ ) where a single CSTR is used for the  $\beta$ -amylase rest.

Glucose level remained unaffected by different temperatures, with two exceptions: a single CSTR for  $\beta$ -amylase rest was used with residence times  $t_{m,\text{total}} = 23$  and 38.3 minutes. However, when two CSTRs were used in a cascade for the  $\beta$ -amylase rest, different temperatures had no significant effect on maltose and glucose levels.

In conclusion the examined temperatures can be used to control extract levels, independent from the number of  $\beta$ -amylase rest CSTRs and mean residence time. In contrast, glucose and maltose concentrations are only significantly affected, when a single CSTR is used for the  $\beta$ -amylase rest.

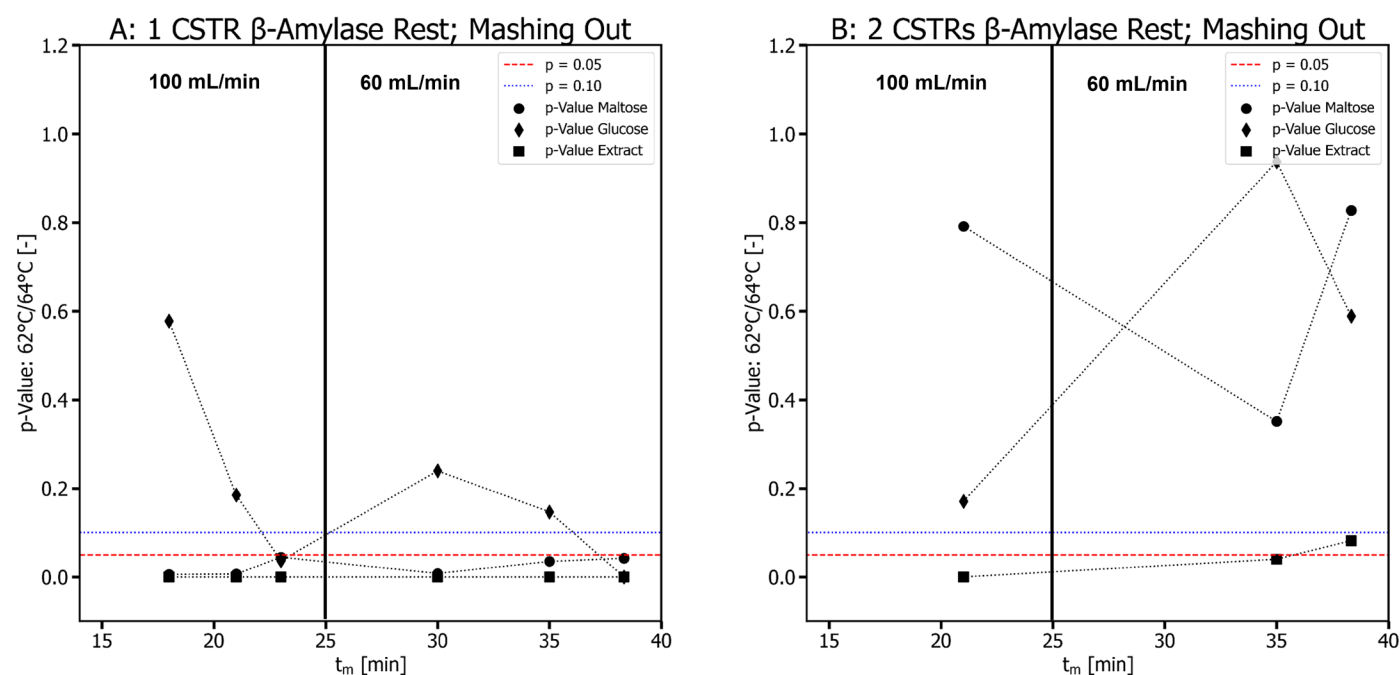

Figure 10.

Comparison of extract, maltose and glucose levels concentrations at the end of the continuous mashing process with the continuous  $\beta$ -amylase rest conducted at 62 and 64°C.

A: single  $\beta$ -amylase rests CSTR; B: two  $\beta$ -amylase rests CSTRs in a cascade.  $t_m$  is the mean residence time; the p-value describing the temperature effect (62/64°C) was determined by Student's t-test.

Table 7.

Student's t-test analysis to determine significant differences affected by the mashing temperature in the continuous  $\beta$ -amylase rest.

<b>1 <math>\beta</math>-Amylase rest CSTR, Mashing out, 62°C/64°C</b>									
$t_m$ [min]	Maltose			Glucose			Extract		
	p-Value	Reject		p-Value	Reject		p-Value	Reject	
		p < 0.05	p < 0.10		p < 0.05	p < 0.10		p < 0.05	p < 0.10
18.00	0.006	True	True	0.578	False	False	$8.81 \cdot 10^{-09}$	True	True
21.00	0.007	True	True	0.185	False	False	$3.65 \cdot 10^{-10}$	True	True
23.00	0.045	True	True	0.037	True	True	$1.16 \cdot 10^{-12}$	True	True
30.00	0.008	True	True	0.239	False	False	$4.27 \cdot 10^{-16}$	True	True
35.00	0.035	True	True	0.147	False	False	$2.03 \cdot 10^{-10}$	True	True
38.33	0.042	True	True	0.000	True	True	$7.48 \cdot 10^{-14}$	True	True
<b>2 <math>\beta</math>-Amylase rest CSTRs, Mashing out, 62°C/64°C</b>									
21.00	0.791	False	False	0.171	False	False	$2.60 \cdot 10^{-05}$	True	True
35.00	0.351	False	False	0.937	False	False	0.040	True	True
38.33	0.827	False	False	0.589	False	False	0.082	False	True

## Discussion

The key to successful continuous mashing is the capability to adapt to the raw materials used for mashing. Barley malt is prone to environmental and genotypic variations that alter its characteristics (Dai et al. 2007; Cai et al. 2013; Henson et al. 2014). All existing continuous mashing systems are broadly inflexible and cannot react on changing raw material properties in the process (Silhavy and Saginaw 1938; Cook and Davis 1960; Watts et al 1964; Hudson and Button 1968; Huppmann 1969; Kehse and Jess 1974; Moll et al. 1976; Mulder 2012; Mulder and Snip 2018)

Here, it was demonstrated, that the CSTR mashing system can control extract and maltose levels via mean residence time. The mashing system consists of a series of steps; protein rest,  $\beta$ -amylase rest, saccharification rest and mashing out. The influence of the individual process steps are discussed in terms of their impact on the fermentable sugar concentration.

The mean residence time was altered by variation in the fill level of the CSTR in the  $\beta$ -amylase rest and by changing the flow rate. As changes in flow rate impact the mean residence time of the process steps, it is necessary to understand its impact on each step.

Additionally, it was demonstrated that the fermentable sugar concentration can be altered by changing the temperature of the  $\beta$ -amylase rest stage temperature. This allows for a second control parameter in the continuous mashing system besides mean residence time.

## Protein rest

In practice, unless poorly modified malt is used, the protein rest is excluded. However, the protein rest was included in the continuous process. A change in the flow rate and the mean residence time of the protein rest had no influence on the formation of maltose, glucose, or extract. This was to be expected as the temperature of the continuous protein rest was 50°C and below that required for gelatinisation of starch. Gelatinisation of mash is an important precondition for the starch degradation (Brandam et al. 2003). Fox et al (2019) reported typical onset gelatinisation temperatures for malt in a range of 54.2 to 60.5°C and for barley in a range between 56.6 to 62.0°C. It is noteworthy that Evans and Fox (2017) found that  $\beta$ -amylase activity during long resting times can be increased by mash temperatures between 45 to 55°C compared to the mashing process without a protein rest. However, this was not found here perhaps because of the short residence time used for the continuous mashing compared to a batch process. Further, changes in the mean residence time during the protein rest is anticipated to influence levels of free amino nitrogen, and the fermentability of the wort. An impact on haze and foam stability of the subsequent beer is possible by reducing the overall length of high molecular weight proteins in the mash (Montanari et al. 2005; Steiner et al. 2011).

## $\beta$ -amylase rest

One of the main aims of this study was whether the mean residence time was sufficiently sensitive as control parameter for a continuous mashing process. The major contribution to fermentable sugars is provided by the  $\beta$ -amylase rest (Henson et al. 2014) and this stage was observed in detail. The enzymes contributing to sugar formation by starch hydrolysis at 62°C to 64°C include  $\alpha$ -amylase,  $\beta$ -amylase and limit dextrinase (Evans et al. 2005; Evans and Fox 2017). The impact of temperature and time on starch degradation has previously been investigated (Jones and Marinac 2002; Montanari et al 2005; Wijngaard and Arendt 2006; Durand et al 2009). A direct comparison of batch and continuous processes is difficult but, as an approximation, the mean residence time and batch rest time can be compared.

While in a batch process it is assumed that temperature and time are the same, there is a degree of heterogeneity due to the ineffective mixing of the grist. In a continuous process the mean residence time describes how long an element (*eg* volume) remains in a CSTR on average (Toson et al. 2019), but is an approximation of how long the 'average volume element' remains in a CSTR. Other volume elements remain longer or shorter in the reactor than indicated by the mean residence time.

The amount of mash leaving the CSTR before or after the estimated mean residence time is dependent on the reactor's flow setting, the geometry, and the number of reactors. The RTD, representing the statistical behaviour of all volume elements can be determined by tracer experiments (Tsai and Chen 2013; Igboke et al 2015). Such experiments are only suitable to predict the RTD depending on a specific set of settings such as flow rate and reactor volume. However, these experiments are costly and time consuming and are not practical for industrial processes.

Extract concentration within the trials conducted with a single CSTR followed a similar rise, due to increased mean residence times. This was expected as maltose is a major contributor to extract (Fox, 2016). Accordingly, the concentration of maltose and extract are influenced by the mean residence time and the effect is greater at higher temperatures.

Results of continuous mashing with a CSTR double cascade (only  $\beta$ -amylase rest) are at a first glance contradictory to the results obtained with a single CSTR. Indeed, significant changes in extract levels were found if the residence time was altered but no significant changes in maltose levels were observed ( $p < 0.05$ ). However, the mean maltose values showed a trend that is comparable to the extract concentrations, which is increasing in response to altered residence time settings for both tested temperatures. Significant differences were found for the maltose values only with a confidence level of  $p < 0.10$  (opposed to the confidence level of  $p < 0.05$  used for single CSTR). No significant changes with a  $p < 0.05$  were found. This may be due to unavoidable measurement errors. The reason for the relatively minor differences between maltose and extract levels when applying short residence

times might be due to the behaviour of individual volume elements inside the CSTR. As noted above, with two CSTRs in a cascade, the residence time most likely is longer than the calculated mean residence time  $t_m$ . That can also explain how higher maltose concentrations were found for the cascade compared with the single CSTR at similar residence times.

## Overall mashing process

As mashing at 65°C and 72°C converts starch into fermentable sugars (Jones and Marinac 2002) the extract, and maltose concentration obtained in the continuous  $\beta$ -amylase rest influence the amount of fermentable sugars formed by the saccharification rest. Indeed, any deficiencies in starch conversation due to shorter mean residence times during the  $\beta$ -amylase rest can be compensated for by the saccharification rest. This was confirmed by mashing at 62°C where the double CSTR cascade reached levels of extract and maltose in the range of mashing at 64°C.

The conversion of starch during the saccharification rest is distinct to the  $\beta$ -amylase rest. The activities of limit dextrinase and  $\beta$ -amylase are increasingly impaired at 72°C (Evans and Fox 2017), with no  $\beta$ -amylase activity after 30 minutes at temperatures of  $\geq 68^\circ\text{C}$  (Henson et al. 2014). With mean residence times beyond 30 minutes during the continuous  $\beta$ -amylase rest, it is unlikely that  $\beta$ -amylase and limit dextrinase contribute to sugar levels in the saccharification rest at temperatures  $\geq 72^\circ\text{C}$ . Accordingly, the results with different mean residence times during the  $\beta$ -amylase rest are only relevant if low extract and maltose levels are targeted in the mashing process. Changes in the volume of the saccharification rest and mashing out were not applied in this study but may contribute to the control of fermentable sugar levels during continuous mashing and should be further investigated.

## Temperature effect in the continuous $\beta$ -amylase rest

Different temperature settings for the continuous  $\beta$ -amylase rest showed that it can be used as control

parameter in a continuous mashing process. Also, it can be assumed that longer reaction times are able to compensate for lower temperatures during the  $\beta$ -amylase rest. This was observed as the different temperatures showed the most pronounced differences when applying the shortest residence times (highest flow rates). On the other hand, with increasing mean residence times, this was not significant with maltose and glucose levels and limited with extract. The increased sugar concentration obtained in the 64°C  $\beta$ -amylase rest reflect higher enzyme activities. Notably, starch degradation depends on the interplay of several different enzymes (Bamforth 2003; Evans et al. 2005) where higher sugar levels do not reflect the activity of a single enzyme. However, the elevated temperature may have increased the enzymatic activity of the diastatic power enzymes ( $\alpha$ -amylase,  $\beta$ -amylase, limit dextrinase).

The applied mean residence times for the  $\beta$ -amylase rest (3–13.3 minutes) were short compared to the batch process. Therefore, the heat inactivation of enzymes may not have been significant. Indeed, Evans and Fox (2017) found that  $\beta$ -amylase activity in malt mashes declines at 65°C by 50% within 60 minutes (Evans and Fox 2017). Surprisingly, in the same study, limit dextrinase activity was demonstrated to increase for the first 20 minutes at 65°C (Evans and Fox 2017). However, this observation was made with a grist:liquor ratio of 1:3, with Evans and Fox (2017) reporting that thicker mashes might be less temperature dependent on enzyme activity.

If at 65°C, half the activity of  $\beta$ -amylase is lost (Evans and Fox 2017), then the short mean residence time in the mashing trials had little impact on enzymatic activity. Nonetheless, the plateau of extract and maltose values at 64°C with a single CSTR were higher compared than at 62°C. A decrease of enzymatic activity either by inhibition or inactivation may explain these results. This was confirmed by the double CSTR cascade for  $\beta$ -amylase rest showing the highest extract and maltose levels at their respective temperatures.

## Conclusions

This study demonstrates that a continuous  $\beta$ -amylase rest in a CSTR can be controlled by mean residence time. The range of mean residence times for the  $\beta$ -amylase rest was three to 13.33 minutes. The continuous  $\beta$ -amylase rest at 64°C allowed a finer adjustment of fermentable sugar levels than at 62°C. If with the  $\beta$ -amylase rest, the mean residence time was low, low fermentable sugar levels in the  $\beta$ -amylase rest were compensated for by the subsequent process steps. It was also demonstrated that temperature as control parameter can be applied in a continuous mashing process. At shorter residence times, the effect of temperature was greater compared to the effect of the extension of the residence times. Currently, the continuous mashing system used in this study is not fully controllable by the mean residence time. If the mean residence time is low, temperature is a suitable control parameter to affect the fermentable sugar concentration.

## Author contributions

**Patrick Wefing:** conceptualisation (lead); investigation (lead); methodology; writing (original draft, review and editing); formal analysis; software; visualisation.

**Marc Trilling:** conceptualisation; investigation.

**Arthur Gossen:** investigation.

**Peter Neubauer:** writing (review and editing).

**Jan Schneider:** writing (review and editing); supervision; conceptualisation.

## Acknowledgements

Financial support by the German Federal Ministry of Education (BMBF), project 13FH3I01IA of smartFoodTechnologyOWL, and the Ministry of Culture and Science of the state North Rhine-Westphalia is gratefully acknowledged.

## Conflicts of interest

The authors declare no conflict of interest. The funders had no role in the design of the study, the collection, analyses, or interpretation of the data and in the writing of the manuscript.

## References

- Bamforth CW. 2003. Barley and malt starch in brewing: a general review. *Tech Q Master Brew Assoc* 40:89–97.
- Bamforth CW. 2009. Current perspectives on the role of enzymes in brewing. *J Cereal Sci* 50:353–357. <https://doi.org/10.1016/j.jcs.2009.03.001>
- Bancila D-M, Popescu D, Chiriac AI, Colbu S-C, Olteanu SC, Petrescu C. 2021. Chemical non-isothermal processes-stability study and optimal control. *Int Conf Syst Theory, Control Comput*, 18–24. <https://doi.org/10.1109/ICSTCC52150.2021.9607060>
- Bee Wah Y, Mohd Razali N. 2011. Power comparisons of Shapiro-Wilk, Kolmogorov-Smirnov, Lilliefors and Anderson-Darling tests. *J Stat Model Anal* 2:21–33.
- Bellut K, Michel M, Zarnkow M, Hutzler M, Jacob F, De Schutter D, Daenen L, Lynch K, Zannini E, Arendt E. 2018. Application of non-*Saccharomyces* yeasts isolated from kombucha in the production of alcohol-free beer. *Fermentation* 4:66. <https://doi.org/10.3390/fermentation4030066>
- Brandam C, Meyer XM, Proth J, Strehaiano P, Pingaud H. 2003. An original kinetic model for the enzymatic hydrolysis of starch during mashing. *Biochem Eng J* 13:43–52.
- Cai S, Yu G, Chen X, Huang Y, Jiang X, Zhang G, Jin X. 2013. Grain protein content variation and its association analysis in barley. *BMC Plant Biol* 13:35. <https://doi.org/10.1186/1471-2229-13-35>

- Colbu S-C, Hamidi F, Popescu D, Jerbi H, Bancila D-M. 2021. Stability analysis and control for non-isothermal CSTR reactors. *Int Conf Syst Control*, 504–509. <https://doi.org/10.1109/ICSC50472.2021.9666616>
- Cook AH, Davis AD. 1960. Process and apparatus for the preparation of worts. US Patent No. 2,961,316.
- Dai F, Wang J, Zhang S, Xu Z, Zhang G. 2007. Genotypic and environmental variation in phytic acid content and its relation to protein content and malt quality in barley. *Food Chem* 105:606–611. <https://doi.org/10.1016/j.foodchem.2007.04.019>
- Durand GA, Corazza ML, Blanco AM, Corazza FC. 2009. Dynamic optimization of the mashing process. *Food Control* 20:1127–1140. <https://doi.org/10.1016/j.foodcont.2009.03.004>
- Evans DE, Collins H, Eglinton J, Wilhelmson A. 2005. Assessing the impact of the level of diastatic power enzymes and their thermostability on the hydrolysis of starch during wort production to predict malt fermentability. *J Am Soc Brew Chem* 63:185–198. <https://doi.org/10.1094/ASBCJ-63-0185>
- Evans DE, Fox GP. 2017. Comparison of diastatic power enzyme release and persistence during modified Institute of Brewing 65°C and Congress programmed mashes. *J Am Soc Brew Chem* 75:302–311. <https://doi.org/10.1094/ASBCJ-2017-4707-01>
- Fox G. 2016. Infrared spectral analysis of sugar profiles of worts from varying grist to liquor ratios using infusion and ramping mash styles. *J Inst Brew* 122:437–445. <https://doi.org/10.1002/jib.341>
- Fox GP, Staunton M, Agnew E and D'Arcy B. 2019. Effect of varying starch properties and mashing conditions on wort sugar profiles. *J Inst Brew* 125:412–421. <https://doi.org/10.1002/jib.585>
- Gupta M, Abu-Ghannam N and Gallagher E. 2010. Barley for brewing: characteristic changes during malting, brewing and applications of its by-products. *Compr Rev Food Sci Food Saf* 9:318–328. <https://doi.org/10.1111/j.1541-4337.2010.00112.x>
- Henson CA, Duke SH, Vinje MA. 2014. A Comparison of barley malt amylolytic enzyme thermostabilities and wort sugars produced during mashing. *J Am Soc Brew Chem* 72:51–65. <https://doi.org/10.1094/ASBCJ-2014-0130-01>
- Hertel M, Sommer K. 2016. Wort boiling method and apparatus. US Patent No.9,434,917 B2.
- Hudson JRH, Button AH. 1968. A novel pilot brewery. *J Inst Brew* 74:300–304. <https://doi.org/10.1002/j.2050-0416.1968.tb03130.x>
- Hui YH. 2007. *Handbook of Food Products Manufacturing*. Hoboken, NJ, USA: John Wiley & Sons, Inc. <https://doi.org/10.1002/0470113553>
- Huppmann F. 1969. Plant for the continuous preparation of brewers's mash and for the cooking of wort. US Patent No. 3,468,240.
- Igbokwe PK, Nwabanne JT, Gadzama SW. 2015. Characterization of a 5 litre continuous stirred tank reactor. *World J Eng Technol*. 03:25–40. <https://doi.org/10.4236/wjet.2015.32003>
- Jones BL. 2005. Endoproteases of barley and malt. *J Cereal Sci* 42:139–156. <https://doi.org/10.1016/j.jcs.2005.03.007>
- Jones BL, Marinac L. 2002. The effect of mashing on malt endoproteolytic activities. *J Agric Food Chem* 50:858–864. <https://doi.org/10.1021/jf0109672>
- Katsch L, Methner F-J, Schneider J. 2020. Kinetic studies of L-ascorbic acid degradation in fruit juices for the improvement of pasteurization plants. *BrewSci* 73:85–94. <https://doi.org/10.23763/BrSc20-13katsch>

- Katsch L, Methner F-J and Schneider J. 2021. Kinetic studies of 5-(hydroxymethyl)-furfural formation and change of the absorption at 420 nm in fruit juices for the improvement of pasteurization plants. *Int J Food Eng* 17:703–713. <https://doi.org/10.1515/ijfe-2020-0324>
- Kehse W, Jess U. 1974. Continuous production of beer wort from dried malt. US Patent No.3,834,296.
- Kempfert NR. 2016. System and method for all-in-one wort preparation. U.S. Patent No.9,499,776 B2.
- Koljonen T, Hämäläinen JJ, Sjöholm K, Pietilä K. 1995. A model for the prediction of fermentable sugar concentrations during mashing. *J Food Eng* 26:329–350. [https://doi.org/10.1016/0260-8774\(94\)00061-D](https://doi.org/10.1016/0260-8774(94)00061-D)
- Koljonen T, Kettunen A, Sjöholm K, Pietilä K, Hamalainen JJ. 1992. Simulation of enzyme kinetics during malt mashing - a new parameter estimation method. *First IEEE Conf Control Appl*, 90–95. <https://doi.org/10.1109/CCA.1992.269893>
- Ma Y, Stewart DC, Eglinton JK, Logue SJ, Langridge P, Evans DE. 2000. Comparative enzyme kinetics of two allelic forms of barley (*Hordeum vulgare* L.) beta -amylase. *J Cereal Sci* 31:335–344. <https://doi.org/10.1006/jcrs.2000.0303>
- MacGregor AW, Bazin SL, Macri LJ, Babb JC. 1999. Modelling the contribution of alpha-amylase, beta-amylase and limit dextrinase to starch degradation during mashing. *J Cereal Sci* 29:161–169. <https://doi.org/10.1006/jcrs.1998.0233>
- Malar S, Thyagarajan T. 2009. Modelling of continuous stirred tank reactor using artificial intelligence techniques. *Int J Simul Model* 8:145–155. [https://doi.org/10.2507/IJSIMM08\(3\)2.128](https://doi.org/10.2507/IJSIMM08(3)2.128)
- Marcinkowska-Lesiak M, Zdanowska-Sąsiadek Z, Stelmasiak A, Damaziak K, Michalczuk M, Poławska E, Wyrwisz J, Wierzbicka A. 2016. Effect of packaging method and cold-storage time on chicken meat quality. *CYTA - J Food* 14:41–46. <https://doi.org/10.1080/19476337.2015.1042054>
- Martin AD. 2000. Interpretation of residence time distribution data. *Chem Eng Sci* 55:5907–5917. [https://doi.org/10.1016/S0009-2509\(00\)00108-1](https://doi.org/10.1016/S0009-2509(00)00108-1)
- Martinez-Amezaga NMJ, Rovaletti MML, Benítez EI, Amezaga NMJM, Rovaletti MML, Benítez EI. 2018. Particle size distribution of polysaccharides in beer before the filtration process. *Int J Food Res* 5:13–19.
- Moll M, Bastin MF, Peters B. 1976. Method of mashing for the production of wort and apparatus for the carrying out of this process. US Patent No.3,989,848.
- Montanari L, Floridi S, Marconi O, Tironzelli M, Fantozzi P. 2005. Effect of mashing procedures on brewing. *Eur Food Res Technol* 221:175–179. <https://doi.org/10.1007/s00217-005-1166-8>
- Mulder H. 2012. Continuous Method of Producing a Mash Extract. US Patent No.8,202,702 B2.
- Mulder H, Snip OC. 2018. Method of producing a mash extract and an apparatus for performing such method. US Patent No.9,879,208 B2.
- Muller R. 1991. The effects of mashing temperature and mash thickness on wort carbohydrate composition. *J Inst Brew* 97:85–92. <https://doi.org/10.1002/j.2050-0416.1991.tb01055.x>
- Osman AM. 2002. The advantages of using natural substrate-based methods in assessing the roles and synergistic and competitive interactions of barley malt starch-degrading enzymes. *J Inst Brew* 108:204–214. <https://doi.org/10.1002/j.2050-0416.2002.tb00542.x>

- Osmekhina E, Neubauer A, Klinzing K, Myllyharju J, Neubauer P. 2010. Sandwich ELISA for quantitative detection of human collagen prolyl 4-hydroxylase. *Microb Cell Fact* 9:1–11. <https://doi.org/10.1186/1475-2859-9-48>
- Quek WP, Yu W, Fox GP, Gilbert RG. 2019. Molecular structure-property relations controlling mashing performance of amylases as a function of barley grain size. *Amylase* 3:1–18. <https://doi.org/10.1515/amylase-2019-0001>
- Roussinova V, Kresta SM. 2008. Comparison of continuous blend time and residence time distribution models for a stirred tank. *Ind Eng Chem Res* 47:3532–3539. <https://doi.org/10.1021/ie070955r>
- De Ruyck H. 1997. Modelling of the residence time distribution in a twin screw extruder. *J Food Eng* 32:375–390. [https://doi.org/10.1016/S0260-8774\(97\)00012-5](https://doi.org/10.1016/S0260-8774(97)00012-5)
- Silhavy JF, Saginaw M. 1938. Method of and apparatus for producing wort or the like. US Patent No. 2,127,759.
- Singh A, Sharma V. 2013. Concentration control of CSTR through fractional order PID controller by using soft techniques. *Fourth Int Conf Comput Commun Netw Technol*, 1–6. <https://doi.org/10.1109/ICCCNT.2013.6726501>
- Steiner E, Gastl M, Becker T. 2011. Protein changes during malting and brewing with focus on haze and foam formation: a review. *Eur Food Res Technol* 232:191–204. <https://doi.org/10.1007/s00217-010-1412-6>
- Stohle L, Wold S. 1989. Analysis of variance (ANOVA). *Chemom Intell Lab Syst* 6:259–272. [https://doi.org/10.1016/0169-7439\(89\)80095-4](https://doi.org/10.1016/0169-7439(89)80095-4)
- Strobl M. 2020. Continuous beer production. *In New Adv Ferment Process*. IntechOpen, 13. <https://doi.org/10.5772/intechopen.86929>
- Taskila S, Osmekhina E, Tuomola M, Ruuska J, Neubauer P. 2011. Modification of buffered peptone water for improved recovery of heat-injured *Salmonella typhimurium*. *J Food Sci* 76. <https://doi.org/10.1111/j.1750-3841.2010.02050.x>
- Toftgaard Pedersen A, de Carvalho TM, Sutherland E, Rehn G, Ashe R, Woodley JM. 2017. Characterization of a continuous agitated cell reactor for oxygen dependent biocatalysis. *Biotechnol Bioeng* 114:1222–1230. <https://doi.org/10.1002/bit.26267>
- Toson P, Doshi P, Jajcevic D. 2019. Explicit residence time distribution of a generalised cascade of continuous stirred tank reactors for a description of short recirculation time (bypassing). *Processes* 7:615. <https://doi.org/10.3390/pr7090615>
- Tsai DDW, Chen PH. 2013. Differentiation criteria study for continuous stirred tank reactor and plug flow reactor. *Theor Found Chem Eng* 47:750–757. <https://doi.org/10.1134/S0040579513060122>
- Watts PH, Ash ME, Philpotts GC. 1964. Method for preparing brewers' wort. US Patent No. 3,128,189.
- Wefing P, Conradi F, Trilling M, Neubauer P, Schneider J. 2020. Approach for modelling the extract formation in a continuous conducted 'β-amylase rest' as part of the production of beer mash with targeted sugar content. *Biochem Eng J* 164:107765. <https://doi.org/10.1016/j.bej.2020.107765>
- Wijngaard HH, Arendt EK. 2006. Optimisation of a mashing program for 100% malted buckwheat. *J Inst Brew* 112:57–65. <https://doi.org/10.1002/j.2050-0416.2006.tb00708.x>
- Willaert RG, Baron G V. 2001. Wort boiling today - boiling systems with low thermal stress in combination with volatile stripping. *Cerevisia* 26:217–230.
- de Winter JCF. 2013. Using the Student's t-test with extremely small sample sizes. *Pract Assessment, Res Eval* 18:1–12. <https://doi.org/10.7275/e4r6-dj05>

Yin C, Zhang G-P, Wang J-M, Chen J-X. 2002. Variation of beta-amylase activity in barley as affected by cultivar and environment and its relation to protein content and grain weight. *J Cereal Sci* 36:307–312. <https://doi.org/10.1006/jcrs.2002.0467>

Ziegler P. 1999. Cereal beta-amylases. *J Cereal Sci* 29:195–204. <https://doi.org/10.1006/jcrs.1998.0238>